



WHITE PAPER

Carbon Fiber Parts Manufacturing With 3D Printed Molds

This white paper provides examples and methods to fabricate on-demand custom molds for composite manufacturing. Through real-life case studies with DeltaWing Manufacturing and TU Berlin, learn how to increase flexibility in composite mold fabrication with 3D printed patterns or by directly 3D printing low-volume molds for wet layup and prepreg laminating.

In the introduction, we will cover an overview of composite materials as well as basic design guidelines that you should know before incorporating 3D printing into your carbon fiber manufacturing process.

Then, the report will cover a step-by-step guide on how DeltaWing Manufacturing and TU Berlin uses 3D printing in the manufacturing process to create carbon fiber parts. This will include a cost analysis and explanation of both the benefits and limitations of their production methods.

Contents

Introduction	3
Composite Materials	3
Fiber-Reinforced Polymer Manufacturing	5
Low-Cost Fabrication of Custom Tools for Carbon Fiber Parts Manufacturing	7
Mold Architecture and Design Guidelines	8
Hand Laminate Carbon Fiber Parts on Molds	
Printed With Tough 1500 Resin	10
Introduction	10
Step-by-Step Method	12
Results	16
Costs Analysis	17
Prepreg Laminate Carbon Fiber Parts on Molds	
Printed With High Temp Resin	18
Introduction	18
Step-by-Step Method	19
Results	21
3D Print Patterns to Cast Molds for Large Series	22
Introduction	22
Step-by-Step Method	22
Cost Analysis	24

Introduction

Composite Materials

Composites are highly versatile and efficient materials, driving innovation in various markets from aerospace to healthcare. They outperform traditional materials such as steel, aluminum, wood, or plastic, and enable the fabrication of high-performance lightweight products.

A composite material is a combination of two or more constituents with characteristics different from those individual components by themselves. Engineering properties are typically improved, such as added strength, efficiency, or durability. Composites are made of reinforcement - fiber or particle - held together by a matrix (polymer, metal, or ceramics). Fiber-reinforced polymers (FRP) dominate the market and have fueled the growth of new applications in various industries. Among them, carbon fiber is a widely used composite in particular for aircraft, racing cars, and bicycles as it is more than three times stronger and stiffer than aluminum and yet 40% lighter. It is formed by reinforced carbon fiber linked with an epoxy resin.

Fibers can be directionally uni-weave and strategically aligned to create strength relative to a vector. Cross woven fibers can be used to create strength in multiple vectors and they are also responsible for the signature quilted look of composite parts. It is common for parts to be produced with a combination of both. There are multiple types of fibers available, including:

FIBERGLASS

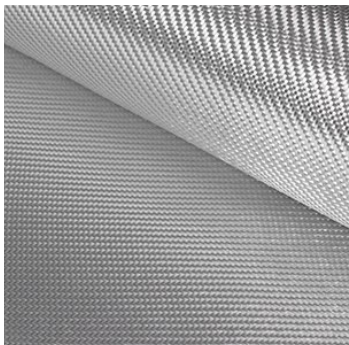

- The most popular fiber
- Lightweight, moderate tensile and compressive strength
- Low cost and easy to work with

CARBON FIBER

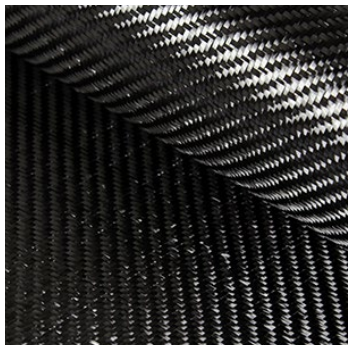

- Highest strength and stiffness-for-weight ratio in the industry (ultimate tensile, compressive, and flexural strength)
- More expensive than other fibers

ARAMID FIBER (KEVLAR)



- Higher impact and abrasion resistance than carbon fiber
- Low compressive strength
- Difficult to cut or machine

Resin is used to hold these fibers together and create a rigid composite. While hundreds of types of resins can be employed, here are the most popular ones:

RESIN	PROS	CONS	CURING
Epoxy	<ul style="list-style-type: none"> • Highest ultimate strength • Lightest weight • Longest shelf life 	<ul style="list-style-type: none"> • Most expensive • Sensitive to mix ratio and temperature variations 	<ul style="list-style-type: none"> • Uses a specific hardener (two-part system) • Some epoxies require heat
Polyester	<ul style="list-style-type: none"> • Easy to use (most popular) • UV resistant • Lowest cost 	<ul style="list-style-type: none"> • Low strength and corrosion resistance 	Cures with a catalyst (MEKP)
Vinyl Ester	<ul style="list-style-type: none"> • Mixes the performance of epoxy and the cost of polyester • Best corrosion, temperature resistance, and elongation 	<ul style="list-style-type: none"> • Lower strength than epoxy and higher cost than polyester • Limited shelf life 	Cures with a catalyst (MEKP)

Fiber-Reinforced Polymer Manufacturing

FRP manufacturing is a skillful and labor-intensive process used in both one-off and batch production. Cycle time ranges from one hour to 150 hours depending on the size and complexity of the part. Typically in FRP fabrication, the continuous straight fibers are joined in the matrix to form individual plies, which are laminated layer-by-layer onto the final part.

The composite properties are induced by the materials as much as the laminating process: the way the fibers are incorporated strongly influences the performance of the part. The thermoset resins are shaped together with the reinforcement in a tool or mold, and cured to form a robust product. There are various laminating techniques available, which can be differentiated into three main types:

1. Wet lay-up

The fiber is cut and laid into the mold then resin is applied via a brush, roller, or spray gun.

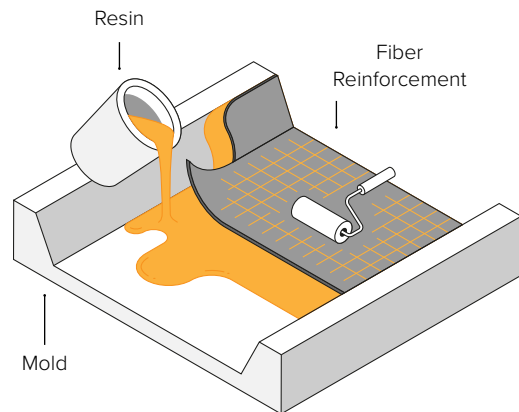

2. Prepreg

The resin is infused in the fiber ahead. Pre-impregnated sheets are stored cold to inhibit the cure. Plies are then cured into the mold under heat and pressure in an autoclave. This is more precise because the quantity of resin is controlled but it is also the most expensive technique that is usually used in high-performance applications.

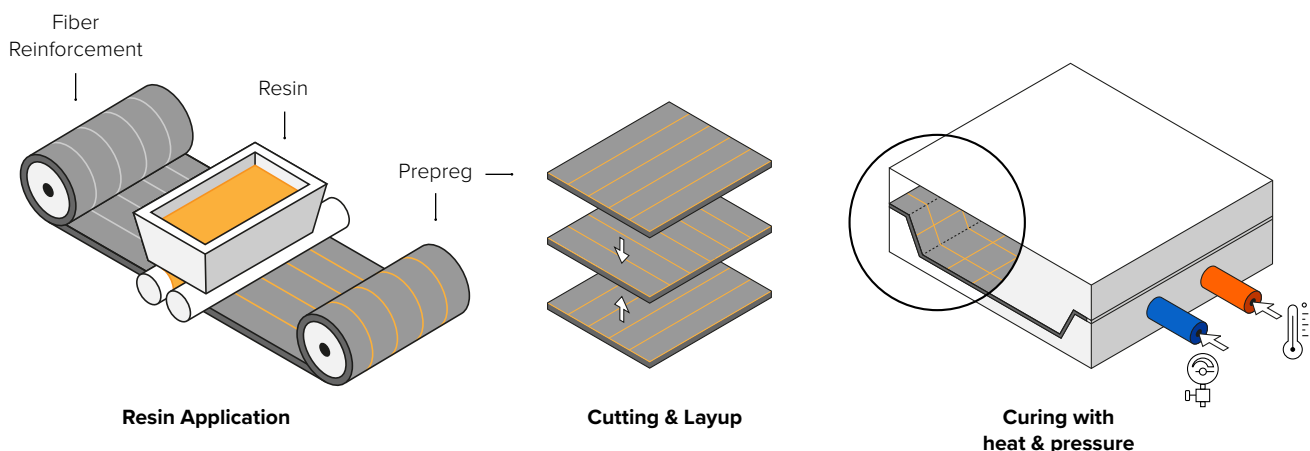

3. Resin transfer molding (RTM)

The dry fiber is inserted into a two-part mold. The mold is clamped shut before forcing the resin into the cavity at high pressure. It is usually automated and used for larger volume manufacturing.

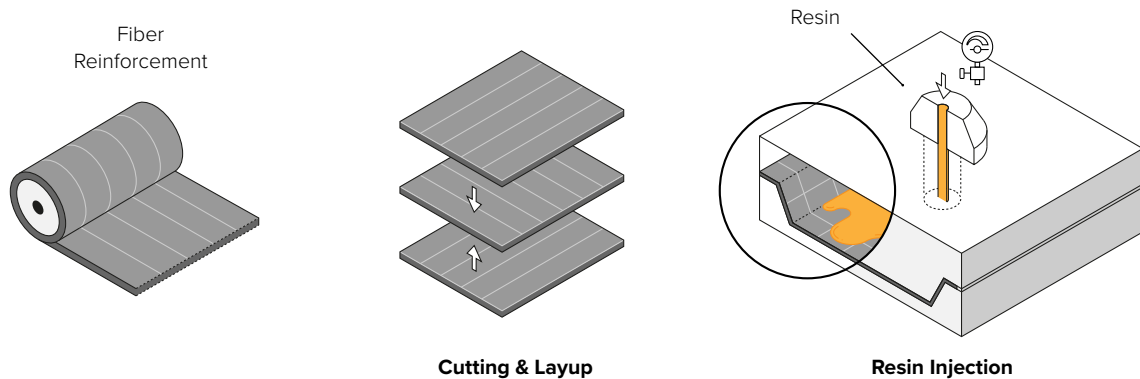

Because the quality of the mold directly impacts the quality of the final part, tool making is a critical aspect of FRP manufacturing. Most molds are produced out of wax, foam, wood, plastic, or metal via CNC machining or handcrafting. While manual techniques are highly labor-intensive, CNC machining still follows a complex, time-consuming workflow—especially for intricate geometries—and outsourcing typically comes at a high cost, with a long lead time. Both options require skilled workers and offer little flexibility on design iterations and mold adjustments.

Additive manufacturing offers a solution for rapidly producing molds and patterns at low costs. The use of polymeric tooling in manufacturing processes is growing continuously. Replacing metal tools with plastic parts printed in-house is a powerful and cost-effective means to shorten production time while expanding design flexibility. Engineers already work with polymer resin 3D printed parts for manufacturing jigs and fixtures to support methods such as filament winding or automated fiber placement. Likewise, short-run printed molds and dies are employed in injection molding, thermoforming or sheet metal forming to deliver low-volume batches.

Low-Cost Fabrication of Custom Tools for Carbon Fiber Parts Manufacturing

In-house desktop 3D printing requires limited equipment and reduces workflow complexity. Professional desktop printers like the [Form 3](#) are affordable, easy to implement, and can be quickly scaled with the demand. Manufacturing large tools and molds is also possible with large format 3D printers such as the [Form 3L](#).

[Stereolithography \(SLA\) 3D printing](#) technology creates parts with a very smooth surface finish, which is essential for a layup mold. It allows for complex geometries with high precision. Additionally, the Formlabs Resin Library has engineering materials with mechanical and thermal properties that pair well with mold and pattern manufacture.

For small-scale production, engineers can directly print the mold at low costs and within a few hours without having to hand carve it or deal with CNC equipment; CAM software, machine setup, workholding, tooling, and chip evacuation. Labor and lead time for mold fabrication are drastically reduced, allowing for quick design iteration and parts customization. They can achieve complicated mold shapes with fine details that would be difficult to manufacture with traditional methods.

The Formula Student team of TU Berlin (FaSTTUBe) manufactured a dozen of carbon fiber parts for racing cars. Engineers in the team hand laminate on a mold directly printed with Formlabs Tough 1500 Resin. This resin is characterized by a tensile modulus of 1.5 GPa and elongation at break of 51%. It is not only strong and supportive during the layup but also sufficiently flexible to separate the part from the mold after curing.

While this technique is not associated with intensive curing conditions, other laminating processes often involve higher pressures and temperatures. The company DeltaWing Manufacturing uses [High Temp Resin](#) to create air flow components through the prepreg process. High Temp Resin has a heat deflection temperature (HDT) of 238 °C @ 0.45 MPa and is able to sustain the heat and pressure of an autoclave. DeltaWing Manufacturing has been directly printing molds to produce a series of about 10 customized parts.

Direct 3D printed polymeric molds are great tools to optimize short-run production. However, their lifetime is reduced from traditional molds, which makes them not suitable for high volume series. To increase production, DeltaWing Manufacturing prints mold patterns with High Temp Resin and then casts them in resin. Printing the pattern is also a powerful alternative for laminating processes requiring intensive curing conditions that are not suitable for 3D printed molds. Manufacturers can print customized patterns on-demand and still eliminate one step from their mold-making technique, the pattern fabrication.

Composite manufacturing, in general, is rather labor-intensive. In prepreg layup, the fibers are pre-coated with the resin and shaped under heat. It is a more repeatable process, but it requires the use of production equipment. Hand lamination requires more skills than the prepreg process but is less expensive. If you are new to carbon fiber parts manufacturing and not equipped yet, we would recommend starting with hand lamination.

Through user cases with TU Berlin and DeltaWing Manufacturing, this white paper presents three workflows to leverage 3D printing in composite manufacturing with the fast fabrication of molds and patterns.

Mold Architecture and Design Guidelines

Different mold architecture is used to create different types of geometry:

- **One-part mold in vacuum bagging:** used for parts that need one class A side, meaning a glossy finish. It can be positive or negative depending on which side should be class A. One side is the mold surface, the other side is the vacuum bag surface.
- **Two-parts mold in compression molding:** used for parts where both sides of the part need to be class A. Both sides are mold surfaces.
- **Bladder mold in pressure molding:** used for complex geometry where a vacuum bag or compression mold can not be employed due to the inability of the part to demold. One side is the mold surface, while the other side is the bladder surface.
- **Mold pattern to create a negative mold:** used when multiple molds are desired to increase production. Multiple molds can be made off a single pattern.

When designing your mold, consider what will print successfully, as well as what will mold successfully:

Add draft angle: Two to three degrees of positive draft angle will facilitate the demolding step and increase the life of the mold, in particular for stiff molds. However, using a pliable 3D printing material such as Tough 1500 Resin can permit you to create parts without a draft and include challenging geometries that could not be demolded from a stiff mold.

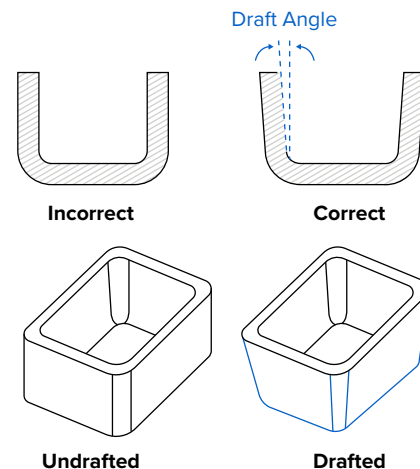

Set a minimum radius appropriate for your material thickness: this helps the fibers to align on corners while avoiding air inclusion, and to create repeatable quality parts. Avoid steep and close proximity corners, as flowing geometries are easier to work with than boxy, edgy ones.

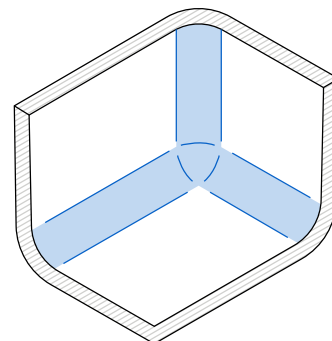
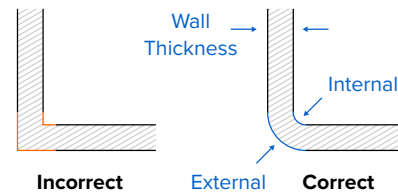

Include locating pins and indents for molds that require precise alignment. One of the great advantages of 3D printing is that it allows for complexity in alignment geometry and helps to fabricate designs sensitive to positioning.

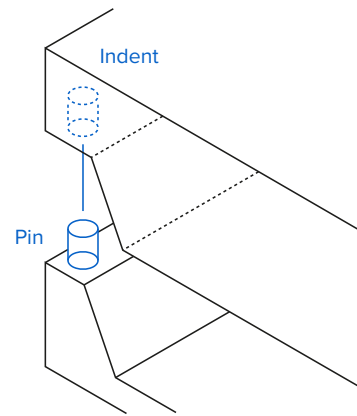

Include surface overrun: excess material from the extended surface will be cut down to draw a precise trim line. 3D printing allows you to print in overrun without needing to fabricate flashing.

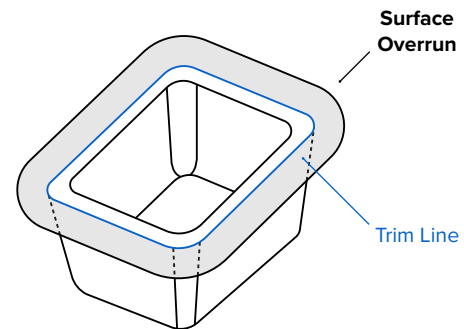

Add trim lines: 3D printing permits you to incorporate precise grooming features such as drill guides, scribe lines for hand trimming, or router guide rails.

Other best practices:

- Print at the smallest layer height possible to optimize the resolution and demolding step.
- Avoid supports on molding faces for better surface finish.
- Use a release agent: this is required to enable the demolding process.
- To avoid air inclusion: after stirring and mixing wait two minutes to have air settle out of the resin. Reiterate after brushing on the first layer of resin. If small air bubbles remain, it can be polished out and sealed off in post-processing.



The FaSTTUBe research lab.

Hand Laminate Carbon Fiber Parts on Molds Printed With Tough 1500 Resin

Introduction

The Formula Student is a yearly engineering design competition in which student teams from around the world build and race formula-style cars. The [Formula Student Team TU Berlin \(FaSTTUBe\)](#) is one of the largest groups; 80 to 90 students have been developing new racing cars every year since 2005. For the first time, this season they are building three models: combustion, electric and autonomous. From fall to summer, they have a year to design, manufacture, assemble, and test the vehicles before the races. Teams are evaluated on the business model, design concept, cost report, and racing performance in particular for power, efficiency, and endurance.

Niklas Werner, the Technical Manager of the FT20c project, introduced us to the FaSTTUBe facilities. The team is using 3D printing for three purposes:

1. **Prototypes:** they print prototypes for various parts such as mountings of the anti-roll bar or stakeholders of the HV Battery.
2. **Molds to manufacture carbon fiber parts:** the team printed a dozen molds to fabricate carbon fiber parts that could not have been made otherwise.
3. **End-use parts:** about 30 final parts of the cars are directly 3D printed from button holders,

shifters of the steering wheel to hose and sensor connectors of the cooling systems.

In this case study, we're looking into the details of the molding application they used to fabricate the steering wheel housing and grips in carbon fiber.

Last season, the team directly printed those pieces with SLS technology in one solid body. Reducing weight is essential in the construction of racing cars. In an effort to lighten the parts, they could have printed hollow steering wheel grips, but it would not be strong enough to bear the grasp of the driver. Carbon fiber is a great material to lower weight while maintaining or increasing strength. To be able to fabricate the part in carbon fiber this year, Felix Hilken, the Head of Aerodynamics and Carbon Manufacturing, developed a workflow using 3D printed molds for wet lay-up lamination and walked us through it. This is a great way to start fabricating carbon fiber parts with minimum supplies.

Equipment

- Formlabs Form 3 SLA 3D printer with Tough 1500 Resin
- Carbon fiber: three layers of 200g, 3K, 0,3mm, twill weave pattern
- Mold release: wax and polyvinyl alcohol
- High strength epoxy resin
- Brush and scissors
- Vacuum bag, vacuum pump, and breather cloth
- Sandpaper



The FaSTTUBe test bench with the carbon fiber parts manufacturing set up.

Step-by-Step Method

This section outlines the method developed for the construction of the steering wheel grips.

1. DESIGN THE MOLD

The grip was manufactured in two halves subsequently assembled, in order to be able to demold the part. For each half of the grip, Felix designed a two-part mold including features that would be challenging to manufacture without 3D printing, in particular:

- Fine features such as tight internal radii, sweeping surfaces, or varying radii surfaces.
- Round tight edges that could not be demolded from an aluminum mold. A hollow 3D printed mold is flexible enough to demold this type of geometry easily.
- Indents for drilling location because the part is sensitive to positioning.

"Some of the features on here can literally not be done with any other process in an economical way," said Felix. He oriented the part to avoid supports on the molding surfaces so that he did not have to post-process the surface of the prints.

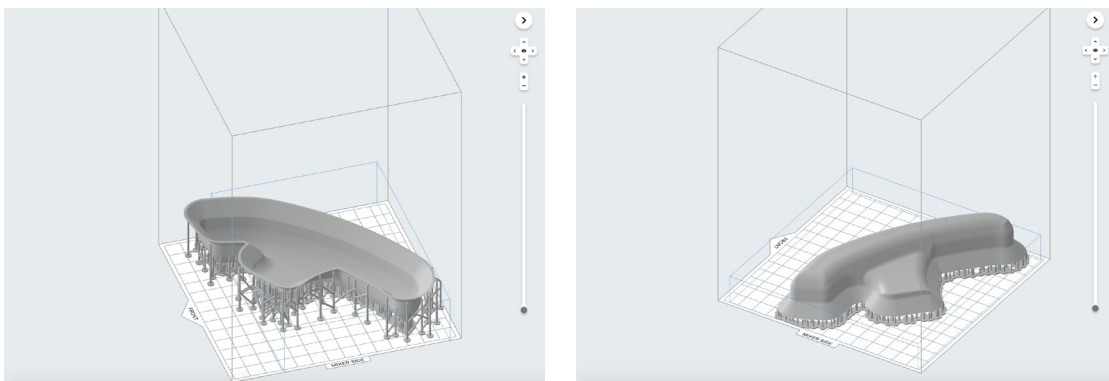

The mold CAD file loaded into the PreForm software for print preparation.



The two-parts mold of the grip steering wheel printed with Tough 1500 Resin.

2. 3D PRINT THE MOLD

The team printed the molds on the Form 3 printer with Tough 1500 Resin at a 50 microns layer height. They had tried FDM technology before but needed the finer resolution that only SLA printing could offer. This process requires an extremely smooth surface to prevent the resin from locking into the layer lines and to facilitate the demolding process. In addition, chances of part warping lessen with SLA technology compared to FDM. SLS 3D printing would not have been suitable either, due to the porous surface of SLS parts. “For fiber composite molds there is a fine finishing process. The better the mold, the better the product,” said Felix. They turned to the Form 3 SLA printer at the smallest layer height. The prints were washed for two periods of 10 minutes in IPA and post-cured for 60 minutes at 70 °C.

Tough 1500 Resin was chosen because it balances elongation and modulus: parts printed in this material can bend significantly and quickly spring back to their original shape. This is a desired mechanical property to avoid mold breakage while demolding. Durable Resin and High Temp Resin were also tested but were either too soft or too brittle. Unlike in the case of the prepreg process, the thermal properties of High Temp Resin are not necessary with wet lay-up as it does not involve heat. Tough 2000 Resin would be a good option for large pieces as it is more sturdy than Tough 1500 Resin.

3. HAND LAMINATE

Here is the step-by-step method that Felix used to create the steering wheel grips.

3.1

Apply release agent to facilitate the demolding process. This is a critical first step, if some surfaces are not covered, the part will not separate from the mold:

- a. Cover with wax
(optional but recommended)
- b. Cover with
polyvinyl alcohol (PVA)



3.2

Mix the resin with the hardener. The mixing ratio must be precisely followed. If it is off by even a few percent of the target ratio, the part will be either too soft or only partially cured. Follow the instruction of the resin manufacturer closely and read the safety sheet before use. With the resin Felix used, the polymerization process starts two hours after the resin is mixed, which leaves two hours for the layup operation.



3.3

Apply resin with a brush on the positive side of the mold.



3.4

Lay up a carbon fiber ply on the positive side of the mold. Make sure to follow all the contours. The team used a 3K fiber to balance weave thickness and price. It is specifically designed to follow complex contours and does not have supporting strands in it.

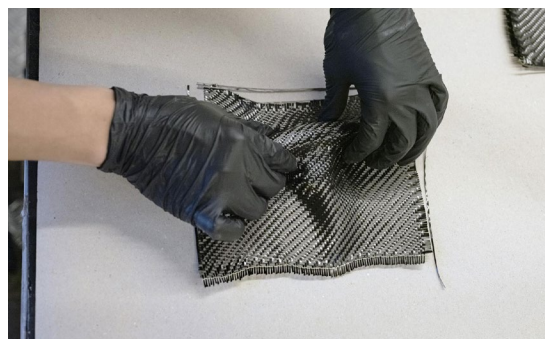

3.5

Apply resin on the carbon ply and reiterate the layup process. The resin bonds the layers together forming the matrix component in the part and prevents the fiber from realigning. Felix used three carbon fiber plies.



3.6

Apply a final layer of resin on the negative part of the mold and press both halves of the mold together to avoid air bubbles forming and permeating through the fibers.



3.7

Cut off the fibers, roughly with a manual tool.



3.8

Cure for 48 hours in a vacuum bag. During this polymerisation process, the vacuum bag pulls out the air and presses the plies against the mold, at ambient temperature, to get rid of excess resin. It ensures a desired volumetric resin to fiber ratio, to match the right part stiffness.



3.9

Finishing: sand off all the edges

In order to clean the mold after the process, Felix dipped it in water for about 30 minutes to dissolve the PVA and then used fine 1500 grit sandpaper to remove the leftover resin.

Using a single negative mold is also an option. In that case, the bag thickness plays an important role for the surface finish as it directly touches the carbon ply. A thicker bag is more durable and therefore preferable for large components such as wings or underbody parts. While thin bagging is more fragile, it follows tight geometries better to avoid the formation of air bubbles and results in a finer surface finish.

Results

By using carbon fiber, the team reduced the weight of the steering wheel housing from 120g to 21g. Felix needed a day to design and build each mold. They were able to push the design to geometries that would be extremely difficult to manufacture traditionally. “The great thing about 3D printing is that a complex shape is as easy to manufacture as a simple one, it requires the same amount of work and equipment,” said Felix.

Without 3D printing, the team would have had to outsource the CNC milling of an aluminum mold, which is expensive, has a long lead time, and requires specialized tools. “I would CNC machine the mold, I would need to get specialized tools, and wait to get a slot on the machine. But I could not even do this geometry. In particular some of the small corners. I would need to use a design that doesn't have any screws in it, so the part would not be sensitive to positioning”.

From his estimation, one mold printed with Formlabs Tough 1500 Resin could be used to fabricate about ten parts. As this is a manual process, it depends on how meticulous the operator is: the mold can break during the separation process. However, multiple 3D printed molds can be used to increase production. Another solution to extend the lifetime of the mold would be to support it with a metallic generic mold. A 3D printed insert carries the geometry while a backup metallic mold helps to hold its shape. This could be fabricated with a simple manual milling machine.



The 3D printed mold and the demolded carbon fiber part for the steering wheel front housing.

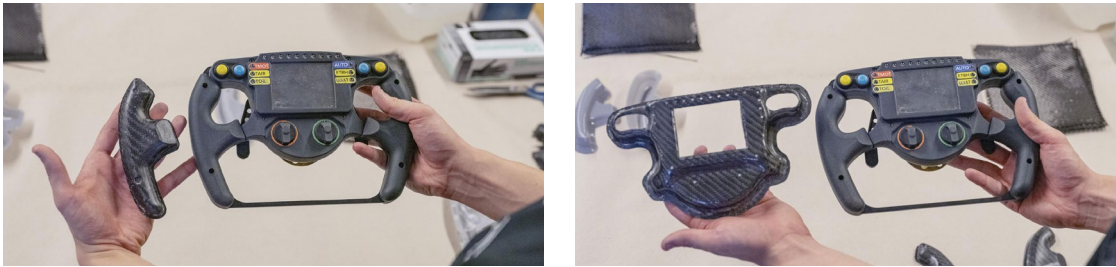

The steering wheel grip (left) and front housing (right) in carbon fiber next to the complete steering wheel housing directly SLS printed from the previous season.

Costs Analysis

Here is a rough cost comparison between outsourcing the metal mold and 3D printing it in house for the steering wheel. We take labor costs and material costs into account and we assume an engineer's billing rate of \$200 an hour.

	OUTSOURCED CNC MACHINED MOLD	IN-HOUSE 3D PRINTED MOLD
Equipment	Carbon fiber, resins, tools, vacuum bag	Carbon fiber, resins, tools, vacuum bag Form 3 printer, Tough 1500 Resin
Mold Production time	4-6 weeks	2 days
Labor Costs	0	\$300
Material costs	0	\$10
Total Mold Production Costs	\$900	\$310

Prepreg Laminate Carbon Fiber Parts on Molds Printed With High Temp Resin

Introduction

DeltaWing Manufacturing is an established composite manufacturer and engineering solutions provider. They have more than two decades of experience delivering solutions to the motorsports, aerospace, SATCOM, and defense industries and are ISO 9001:2015 and AS 9100:2016 Certified.

DeltaWing Manufacturing creates composite parts for the company Panoz, a designer and manufacturer of exclusive, American-made luxury sports cars. Panoz was the first US auto manufacturer to use super formed aluminum panels for its bodies and created America's first Aluminum Intensive Vehicle (AIV), the Panoz AIV Roadster. Since then, Panoz has gone on to create the American Le Mans Series (ALMS) and currently race the Panoz Avezano in the Pirelli World Challenge series.

To fabricate carbon fiber components, DeltaWing Manufacturing used to machine a pattern, layup or cast a mold on it, and finish the mold before applying the prepreg process to laminate the carbon fiber part. In the past years, they started using in-house 3D printed parts as intermediate in this process, such as:

1. Directly 3D printed mold for prototypes and low-volume batches.
2. Printed pattern to cast molds for large series.

Panoz needed six units of a carbon fiber fender air duct for a custom racing car. In order to reduce labor and lead time from their traditional mold making technique, the engineers from DeltaWing Manufacturing chose to directly 3D print the mold and implement it in their prepreg process. The next section describes the procedure they utilized.

Equipment

- Formlabs SLA 3D printer with High Temp Resin
- Carbon fiber: 4K, bidimensional pattern
- Mold release: polyvinyl alcohol
- Kapton (polyimide) tape
- High strength epoxy resin
- Brush and scissors
- Vacuum bag, vacuum pump, and breather cloth
- Autoclave
- Sandpaper



Panoz Avezzano racing car

Step-by-Step Method

1. DESIGN THE MOLD

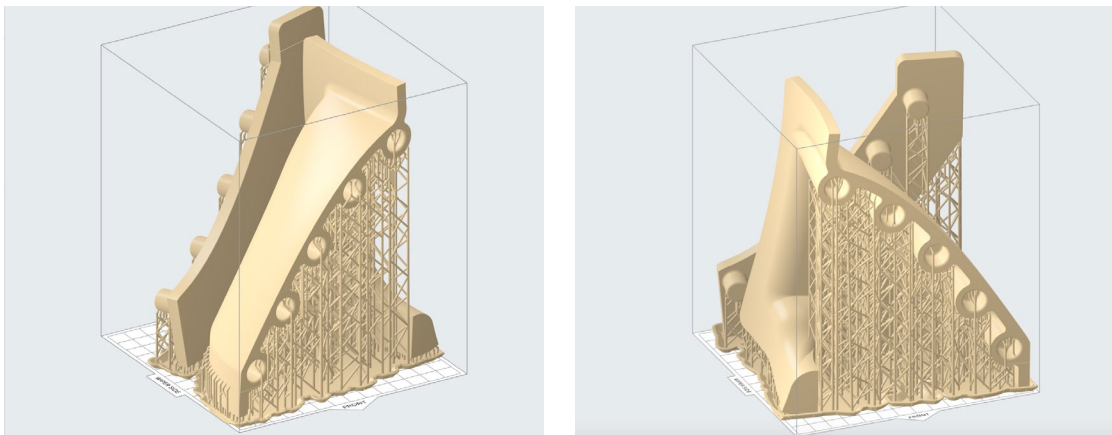

The CAD files of the two-parts molds, loaded into the PreForm software for print preparation.

The duct was fabricated in two distinct pieces on two different molds in order to facilitate the separation of the final part from the mold, and then subsequently bonded. Each mold was also printed in two pieces and assembled together so that it can fit in the build volume of the Form 3 printer—however, this would not be necessary with the larger build volume of the Form 3L printer. The parts were designed for additive manufacturing, following mold design recommendations.

2. 3D PRINT THE MOLD



The two-parts mold printed with High Temp Resin.

DeltaWing printed the molds in High Temp Resin on the Formlabs printer at 100 micron layer height. This resin was selected because it has a heat deflection temperature (HDT) of 238 °C @ 0.45 MPa, the highest among Formlabs resin and one of the highest among resins on the market. High Temp Resin can withstand high curing temperatures, shows a good stiffness to hold shape during the operation and a great level of details that will be translated into the final part. Formlabs recommends washing High Temp Resin prints with IPA for 10 minutes, post-cure at 80 °C for 120 minutes, and then heat the parts for 3 hours at 160 °C for a higher HDT.

3. PREPREG LAMINATE



The left half of the carbon fiber duct (right) demolded from the 3D printed mold covered in Kapton tape (left).

DeltaWing Manufacturing applied their usual prepreg process on the printed molds, using a prepreg 4K bidimensional pattern fiber. Each mold was covered in Kapton tape in order to renew the surface at each molding iteration. The fiber was laid up on the molds and then the parts were put in a vacuum bag and cured in an autoclave before demolding and trimming. The printed molds tolerated a slow cure at 38 °C (100 °F) for 10 hours, or alternatively, a fast cure at 126 °C (260 °F) for 1 hour without damage. Both halves of the carbon duct were bonded in a final step.

Results

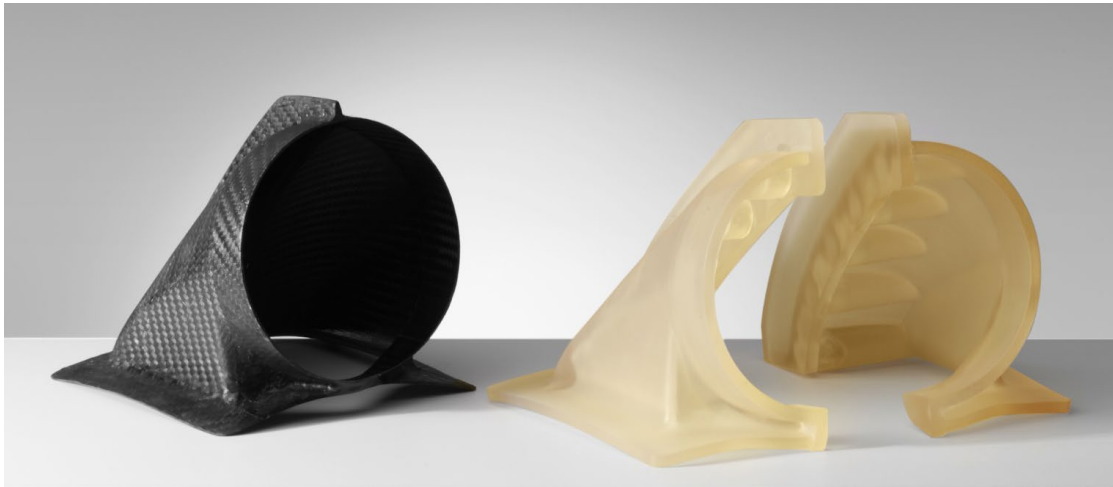

The carbon fiber fender air duct next to the two-parts mold printed with High Temp Resin.

The team tested six iterations for one mold without observing any significant degradation. We estimate around 10-15 iterations possible for one mold. As autoclaves are used to apply heat and pressure during curing in the prepreg process, the printed mold can only withstand a few iterations. Therefore, this method is not recommended for high-volume production, but it is a great way to produce short-run batch and mass-customized parts. This enables a wide range of applications such as high-performance sports equipment, customized tooling for aerospace, or personalised prosthetics that are unique to the patients in healthcare.

For projects with higher units demand where 3D printing molds may not be sufficient, DeltaWing Manufacturing has been printing patterns for mold casting, described in the next section.

3D Print Patterns to Cast Molds for Large Series

Introduction

Panoz needed to manufacture an air exit duct for the cockpit of a custom racing car in order to vent air out of the cabin and cool down the temperature inside. This time, in order to increase production, DeltaWing Manufacturing 3D printed a pattern in-house and then casted the mold on the printed pattern. While being close to the traditional manufacturing process, this workflow shortens time in pattern fabrication and allows for more design complexity. It is a great way to produce a high volume of parts; fabricating multiple long-lasting molds with intricate geometries.

Step-by-Step Method

1. DESIGN THE PATTERN

The pattern was designed for additive manufacturing and could be printed directly on the build platform. No supports were required when loaded into the print preparation software PreForm. Because 3D printing allows for the inclusion of complex features without adding significant cost, they could incorporate a 90 degrees angle foot to level the part during the casting process.

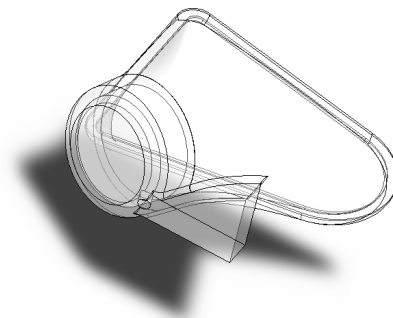

2. 3D PRINT THE PATTERN

DeltaWing printed the parts in Formlabs High Temp Resin on the Formlabs printer at 100 micron layer height within a few hours. This resin was selected as it complies with the following performance requirements:

- A smooth surface finish to translate the pattern details into the mold
- A good stiffness, so that the pattern hold its shape while casting
- A HDT higher than 100°C to withstand the curing temperature of the casting process



Formlabs recommends washing High Temp Resin prints with IPA for 10 minutes, post-cure at 80 °C for 120 minutes, and then heat the parts for 3 hours at 160 °C for a higher HDT.

The 3D printed parts had a smooth surface similar to parts sanded with a 2000 grit sandpaper without additional post-processing, saving a lot of time in the preparation process.

3. CAST THE MOLD

The pattern was buffed with a polyvinyl alcohol mould release agent, then the casting resin was poured in it. They used the [System 3300 High Temp Tooling Epoxy](#) from Fibreglast.

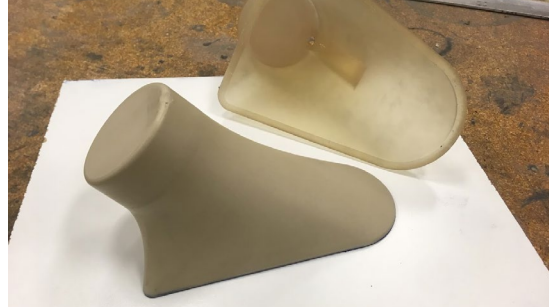

4. PREPREG LAMINATE

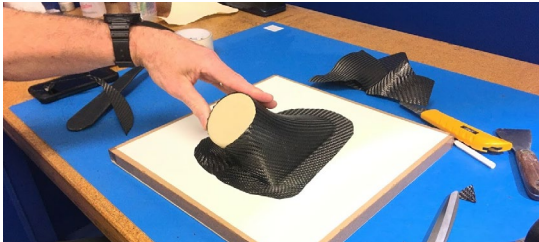

DeltaWing Manufacturing applied their usual prepreg process on this mold. They laid the prepreg fiber up the mold (1) then vacuum bagged (2) and cured it in an autoclave (3). The part was then demolded and trimmed (4).

Final carbon fiber part assembled on Panoz Avezzano racing car.

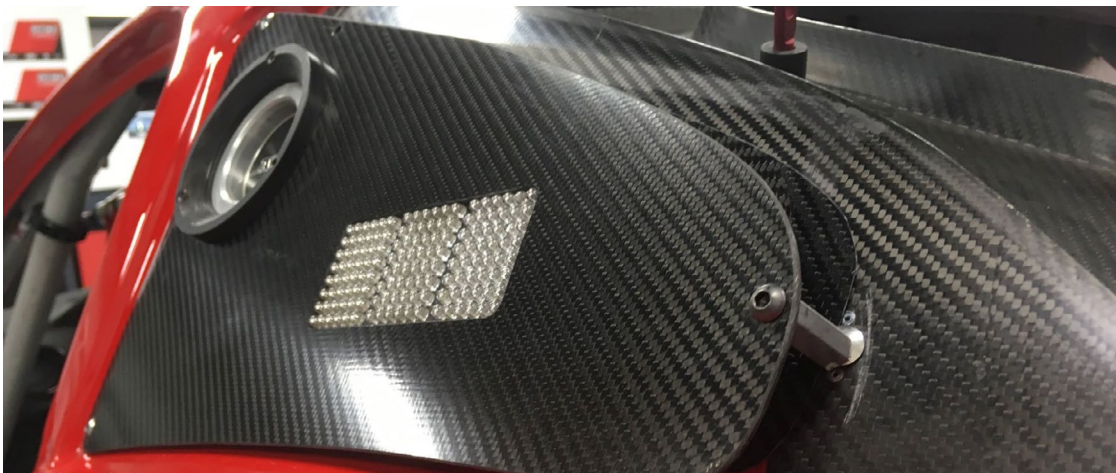

Cost Analysis

Here is a rough cost comparison between machining the mold pattern in house and in-house 3D printing. We are using a basic part from DeltaWing, taking labor costs and material costs into account and we assume an engineer's billing rate of \$200 an hour. DeltaWing requires a very fine surface finish which involves additional post-processing time when machining. This finishing was unnecessary with SLA 3D printed parts, as they avoided supports on the molding surfaces.

CNC machining in house

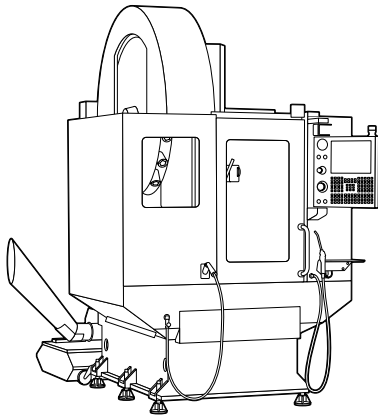

CNC machining involves about an hour and a half of labor for work holding, block preparation, and CAM programming. Then about four additional hours for hand finishing and sealing.

Machining labor time	5.5 hours
Machining labor costs	\$1100
Blue Block material costs	\$220
Total costs of machining	\$1320

3D printing in house

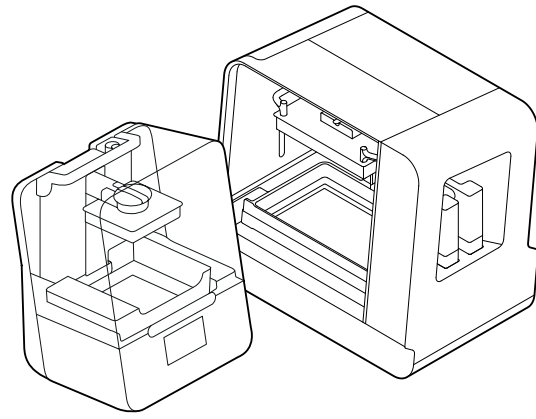

3D printing with Formlabs requires less than half an hour to prepare the print in PreForm and about an hour of labor for post-processing with washing, curing, and support removal.

3D printing labor time	1.5 hours
3D printing labor costs	\$300
Formlabs resin costs	\$50
Total cost of 3D printing	\$350

While manufacturing time is shorter with CNC machining than 3D printing, the labor time needed for operating the CNC machine and finishing the part to the level required for carbon fiber fabrication is much longer. As a result, labor costs are substantially higher with CNC machining. Thanks to 3D printing, they managed to reduce by almost four times their costs on a basic part.



Conclusion

Fiber-reinforced polymer manufacturing is an exciting, yet intricate, and labor-intensive process. Using 3D printed molds and patterns allows businesses to reduce workflow complexity, expand flexibility and design opportunities, and reduce costs and lead time. With the recent release of the Form 3L, Formlabs's large format SLA 3D printer, this process can now be easily scaled to large molds to better enable innovations in markets such as automotive and aerospace.

Do you have questions about using an SLA printer for composite manufacturing or other engineering and manufacturing applications? Reach out to our solutions specialists for an information session to answer your questions.

AZ ÖN HAZAI FORMLABS FORGALMAZÓJA

3DEE TECHNOLOGIES HUNGARY KFT. – GONDOLKODJUNK ADDITÍVAN!

Több mint **8 év additív gyártási** és több mint **500.000 3D nyomtatási óra** tapasztalatával, valamint **15.000 elégedett Ügyféllel** a hátunk mögött nap mint nap azért dolgozunk, hogy segítsük a 3D technológiák hazai elterjedését. A **Formlabs készülékei 2015 óta** képezik stabil részét gépparkunknak. Magyarország és Közép-Európa első 3D nyomtató szaküzletével, illetve lelkes csapatunkkal igyekszünk Ügyfeleink minden igényét kielégíteni:

- **INGYENES FORMLABS TERMÉKBEMUTATÓ**
- **EGYEDI PRÓBANYOMTATÁS**
- **HELYSZINI BEMUTATÓ**
- **HELYSZINI BEÜZEMELÉS**
- **FELHASZNÁLÓI OKTATÁS**
- **SUPPORT ÉS SZERVIZCSOMAGOK**
- **GARANCIÁLIS TÁMOGATÁS, ÜGYINTÉZÉS**
- **3DEE ÁRGARANCIA – A PIAC LEGJOBB ÁRAIVAL**

Keresse specialistáinkat!

www.3dee.hu – office@3dee.hu – +36 20 38 03 400

